

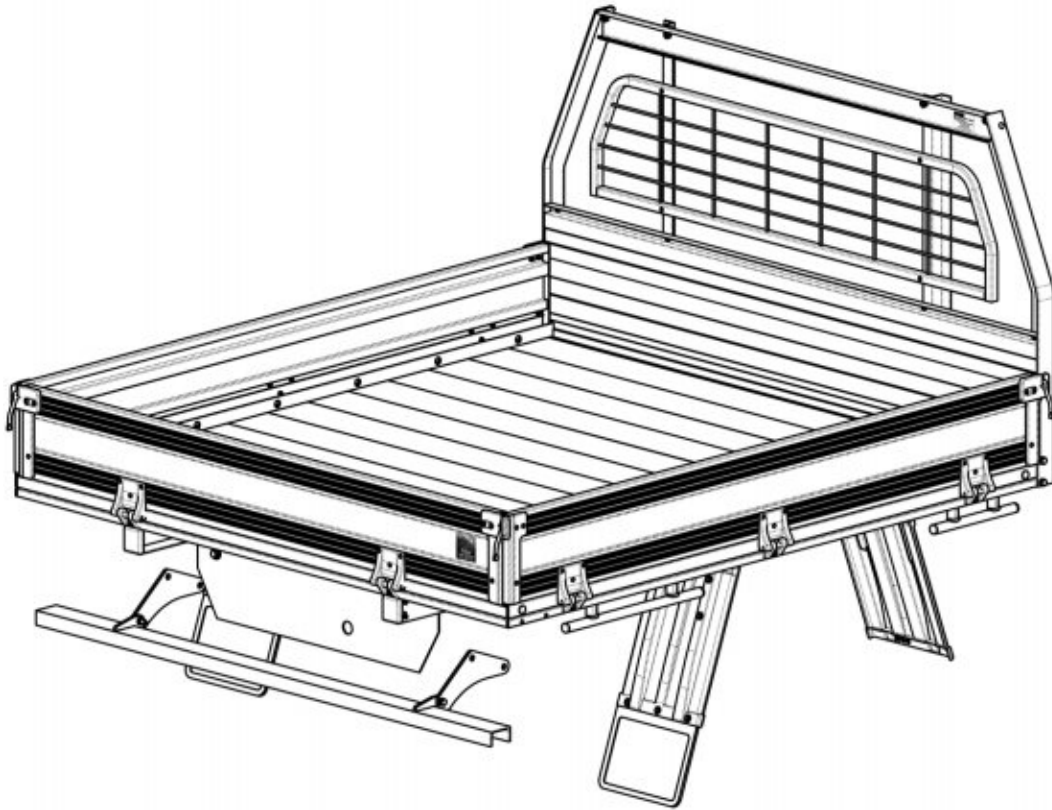

ASSEMBLY INSTRUCTION

Colorado / Canyon 1950 QL GPA-HDA Tray

PART NO.	DESCRIPTION
PUSG1SHQ	B6GM-A 1950x1842 HDA Ang HB QL



*Note: Mount Kit not included in tray code

Tray Installation Time: 2 Hours

Important  Please read these instructions carefully before installation, paying special attention to all Notice, Caution & Warning notes: Failure to do so may result in damaged parts or injury to the installer or customer.

Caution  Installation of the tray body requires the use of power tools. When using power tools, ensure that all necessary safety equipment is used (including personal protection items) and that adequate care is taken.

TOOLS REQUIRED			
Electric Drill	10mm Socket	10mm Spanner	8mm blade screwdriver
6.5mm drill bit	12mm Socket	12mm Spanner	#2 Phillips screwdriver
12.5mm drill bit	14mm Socket	13mm Spanner	Hammer
Air impact wrench	19mm Socket	14mm Spanner	Soft Faced Hammer
Tapered bar	18mm Spanner	16mm Spanner	Side Cutters
Builder square	19mm Spanner	18mm Spanner	Pliers

Model Name Colorado / Canyon	Issue 1	Date 11/01/2016	Page 1 of 17
---------------------------------	------------	--------------------	-----------------

ASSEMBLY INSTRUCTION

Colorado / Canyon 1950 QL GPA-HDA Tray

Section 1 - Assembly of Tray Mount Kit

CODE	DESCRIPTION	QTY
9PMKUS60	pMK US Clrdo MY15 EC	1

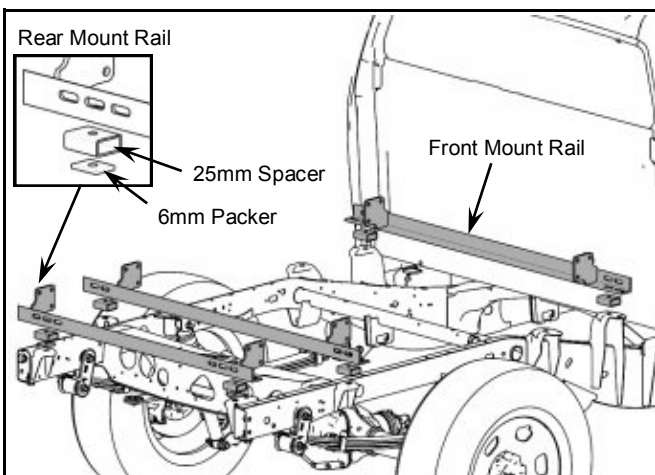
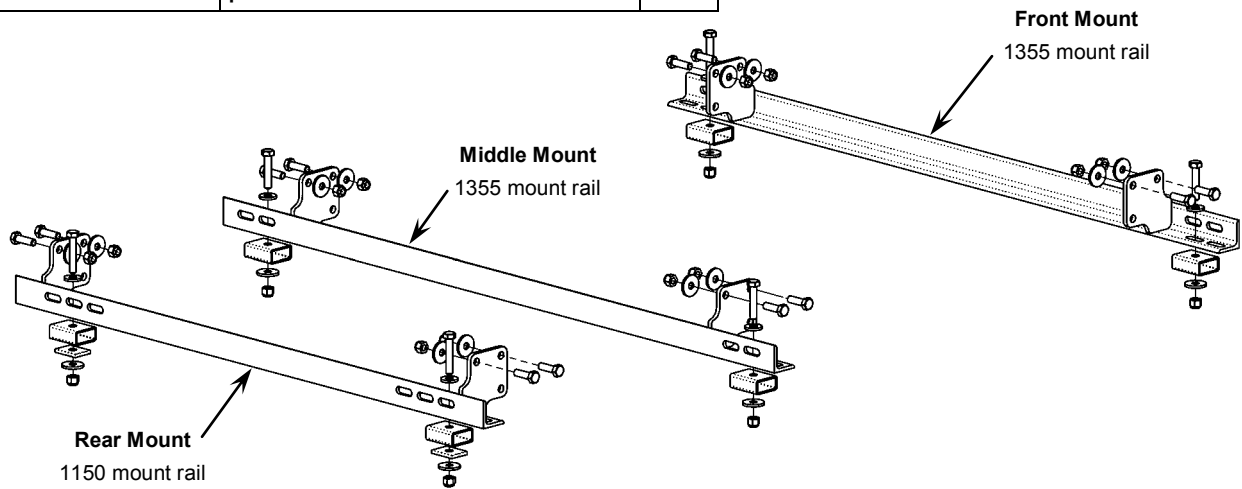

Diagram 1.1: Mounts to Chassis assembly

STEP 1:

- Place 1355 Mount Rails onto the vehicle front and 3rd chassis pad, ensuring to add the 25mm spacers between the rail and chassis pad, as shown in adjacent diagram.
- Assemble the 1150 mount rail to the rear mount pad, using 25mm spacer and 6mm packer between rail and chassis pad.

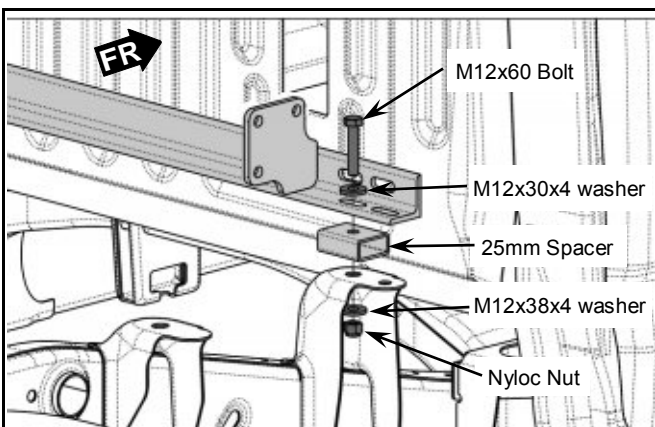

Diagram 1.2: Front rail mount assembly

STEP 2:

- Install fasteners through front and middle mount rails to the chassis pads using M12x60 Bolt, M12x30x4 washer, M12x38x4 washer and M12 Nyloc nut.
- Do not tighten at this stage.

ASSEMBLY INSTRUCTION

Colorado / Canyon 1950 QL GPA-HDA Tray

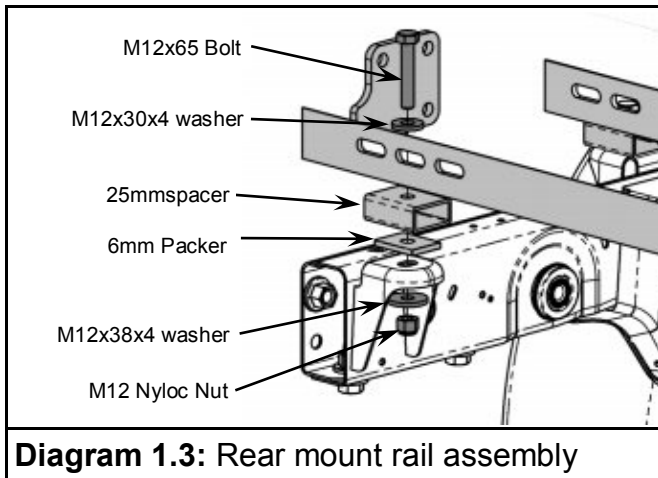

STEP 3:

- Install fasteners through rear mount rail to the chassis pads using M12x65 Bolt, M12x30x4 washer, M12x38x4 washer and M12 Nyloc nut.
- Ensure the 25mm spacer and 6mm packers are placed on the rear chassis mount faces.
- Do not tighten at this stage.

ASSEMBLY INSTRUCTION

Colorado / Canyon 1950 QL GPA-HDA Tray

Section 2 - Headboard to Tray Deck Assembly

Packs required:

CODE	DESCRIPTION	QTY
9PATHQ195CU	AT QL 1950x1842 HDA UTE LTD Clrdo	1
9PAHRAQCJ2	AAHR QL Ang 1842-980	1
9PAHJ	AH Ang-Sq 980 Uprights	1
9PEWP350A	Pack Window Prot 350 Bow	1

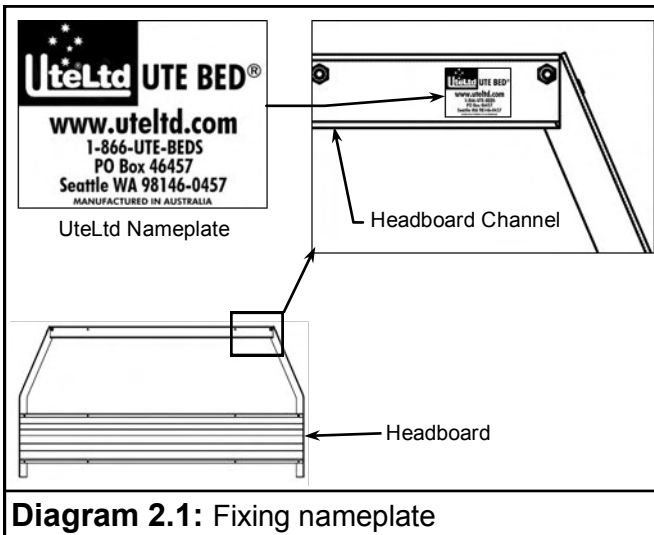
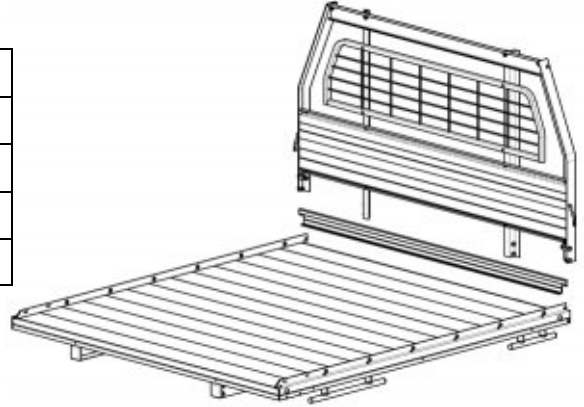

Diagram 2.1: Fixing nameplate

STEP 1:

- On front of the Headboard, apply UteLtd nameplate to top right hand side of headboard channel. Ensure nameplate is central and square as shown in diagram 2.1.
- Ensure area is free of dirt and grease prior to applying nameplate.

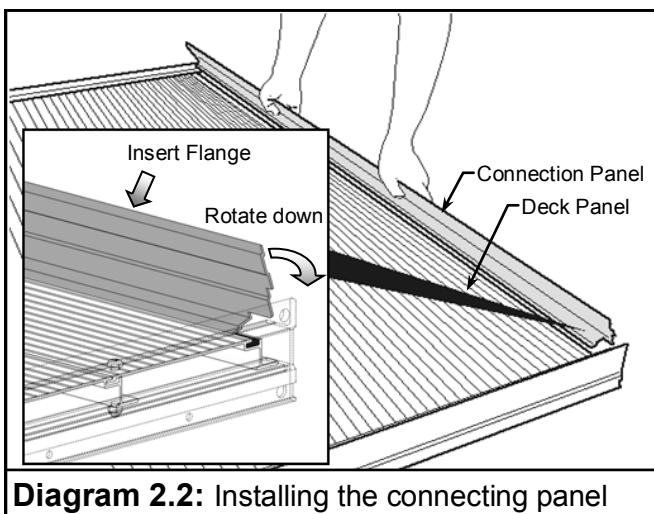

Diagram 2.2: Installing the connecting panel

STEP 2:

- Place the tray body deck on trestle stands, in order to safely work above and below the deck height.
- Remove & discard any transport brackets from the underside of the main bearers.
- Insert the flange of the headboard connection panel into the slot of the front-most deck panel, as per diagram 2.2.
- Ensure the connection panel is placed centrally to the deck panel.

ASSEMBLY INSTRUCTION

Colorado / Canyon 1950 QL GPA-HDA Tray

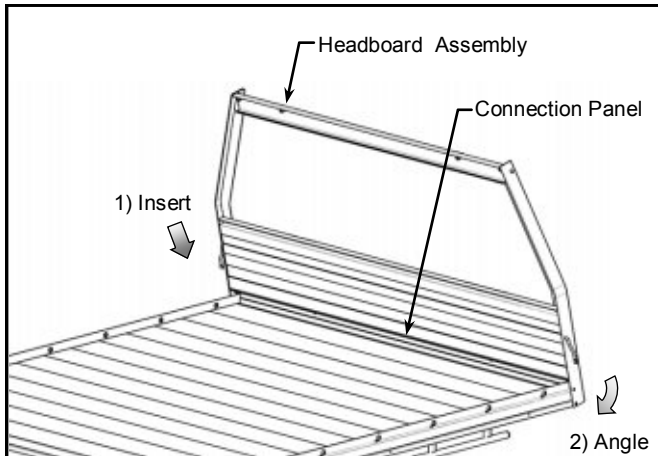

Diagram 2.3: Installing the headboard

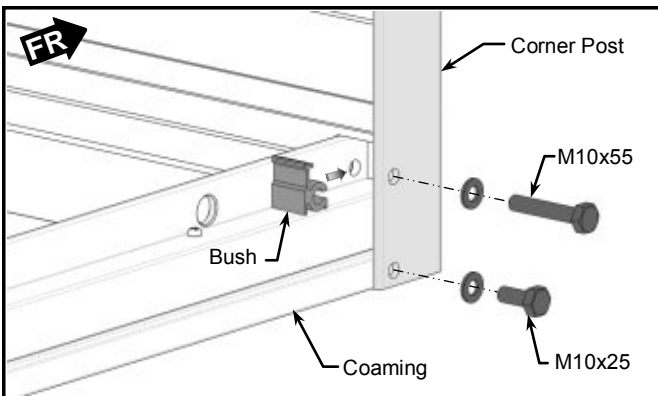

Diagram 2.4: Headboard Fastener Installation

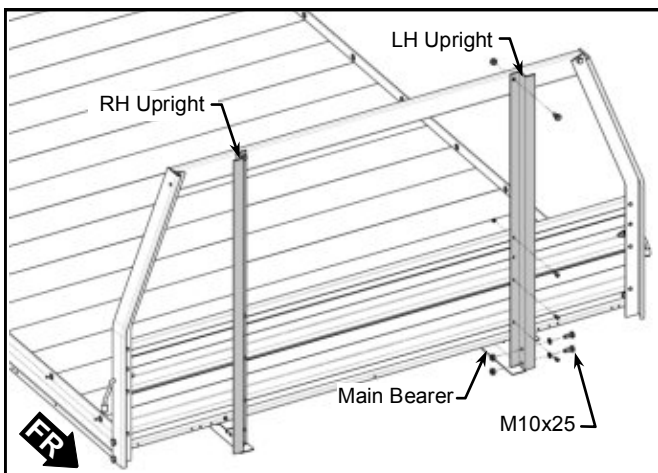

Diagram 2.5: Headboard Fastener Installation

STEP 3:

- With the help of another person or mechanical aid, insert the flange of the headboard connection panel into the slot of the bottom headboard panel, as per diagram 2.3.
- Angle the headboard panel assembly upright, so the headboard panel assembly sits perpendicular to the deck.
- Ensure the headboard panel assembly is placed centrally to the deck.

STEP 4:

- Ensure the headboard assembly is perpendicular to the deck by using a builders square.
- Insert the headboard/coaming bush into the space between the headboard corner post and the side coaming. Place a M10x55 Bolt with washer, through the headboard corner post, bush and side coaming and fasten with a M10 Nyloc nut.
- Fix the bottom hole with a M10x25 bolt, washer and Nyloc Nut.
- Torque fasteners ensuring the headboard remains perpendicular to the deck.

STEP 5:

- Fasten the headboard uprights to the main bearers using M10x25 bolts, washers and nyloc nuts.
- Ensure fasteners are tightened to the correct torque.

ASSEMBLY INSTRUCTION

Colorado / Canyon 1950 QL GPA-HDA Tray

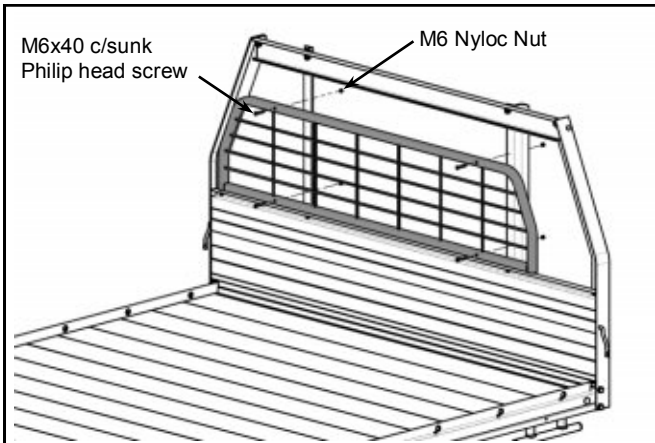

Diagram 2.6: Window Protector Installation

STEP 6:

- Install Window Protector to uprights using M6x40 countersunk Philip head screw and M6 Nyloc Nut.

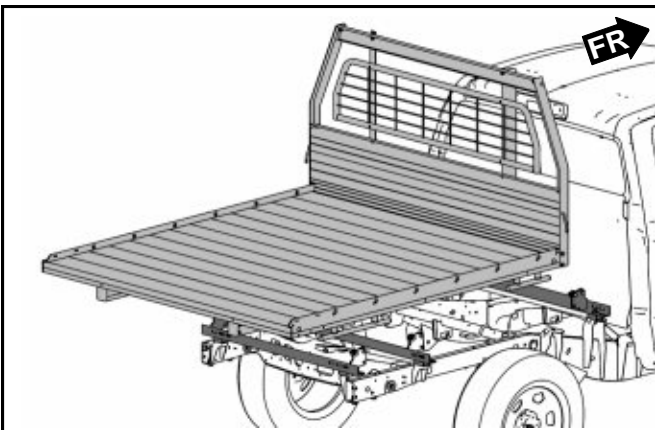

Diagram 2.7: Check headboard is square

STEP 7:

- With an adequate number of people, or a mechanical aid, lower the tray body deck assembly onto the pre-secured mounts on the vehicle chassis.
- To lessen the risk of cabin damage, place the tray body down on the mounts 150-200mm rearward from the cabin.

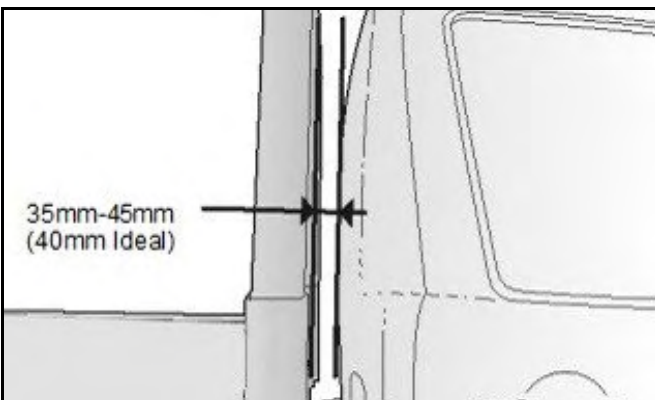

Diagram 2.8: Tray to mount assembly

STEP 8:

- Slide the tray body along the mounts, toward the vehicle cabin.
- Position the tray body such that there is a 40mm gap between the vehicle cabin and the uprights of the headboard, as shown in the adjacent diagram.

ASSEMBLY INSTRUCTION

Colorado / Canyon 1950 QL GPA-HDA Tray

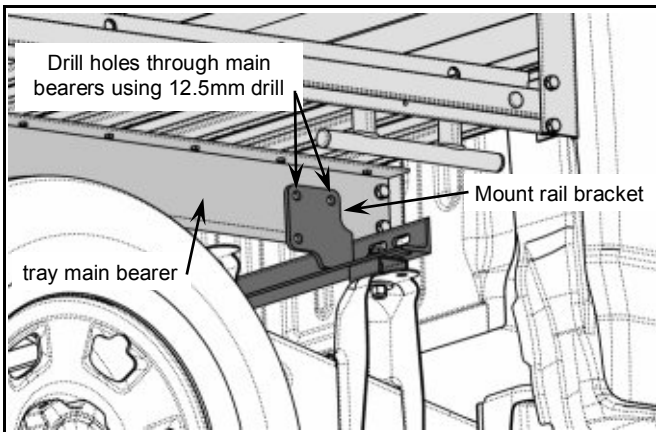

Diagram 2.9: Tray to mount assembly

STEP 9:

- Once the tray has been correctly positioned to the cabin, use the mount rail bracket as a template and drill $\text{Ø}12.5\text{mm}$ holes through tray main bearer, as shown in adjacent diagram.

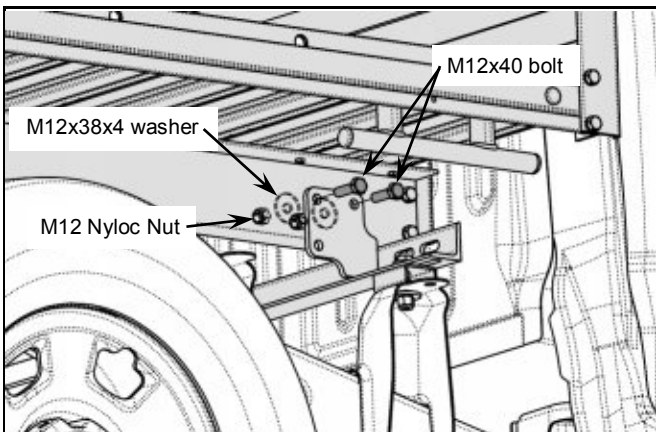

Diagram 2.10: Tray to mount assembly

STEP 10:

- Fasten tray to the mount rail brackets using M12x40 bolts on the outside, and M12x38x4mm washer and M12 Nyloc nut from the inside of the main bearer side.
- Ensure tray is level and central to vehicle cabin, and then tighten all mount rail bolts connected to the chassis pad.

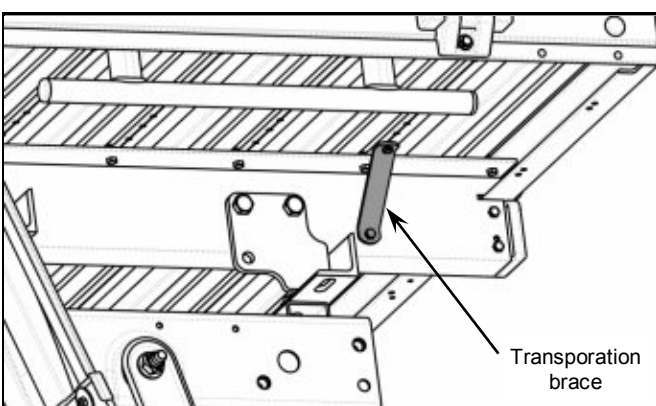

Diagram 2.11: Removing packing brace

STEP 11:

- Once the tray body has been fitted to the vehicle, remove and discard the transportation brace (if fitted) from underneath the tray body.
- Ensure this step is completed as the brace will rust if left on the tray body.
- This brace is used only for support while the tray body is being transported and serves no other purpose.

ASSEMBLY INSTRUCTION

Colorado / Canyon 1950 QL GPA-HDA Tray

Section 3 - Mud Guard, rail assembly

Packs required:

CODE	DESCRIPTION	QTY
9PBKUSG01	pBK UTE LTD Generic Kit [PP]	1

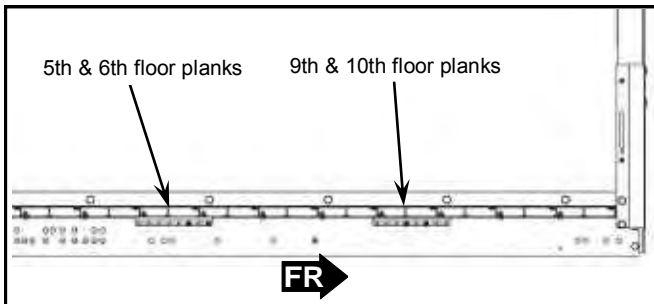
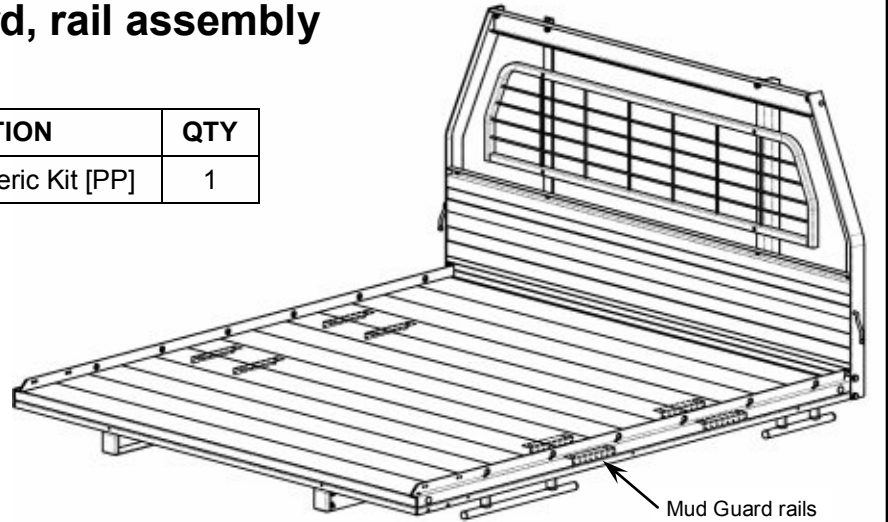

Diagram 3.1: Fitment of guard rail (side view)

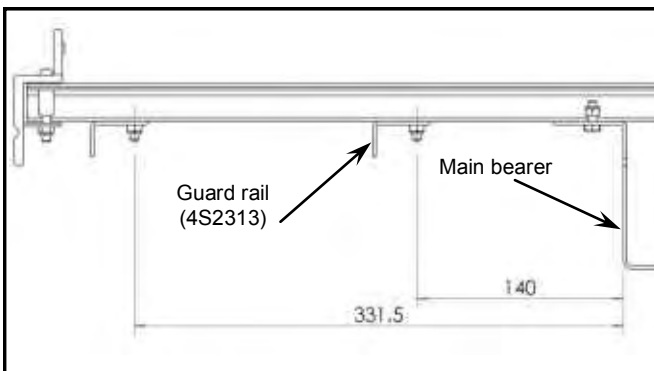

Diagram 3.2: Fitment of guard rail (rear view)

STEP 1:

- Starting from the rear of the tray, position the rear guard rail bracket so the holes in the rail bracket are aligned with the 5th & 6th floor plank holes and the front guard rail holes are aligned with the 9th & 10th floor plank holes.
- Confirm correct positioning of guard rail orientation by measuring from main bearer to outside of guard rail. This dimension should be 140mm, as shown in diagram 3.2.

ASSEMBLY INSTRUCTION

Colorado / Canyon 1950 QL GPA-HDA Tray

Section 4 - Mud Guard Kit Assembly

Packs required:

CODE	DESCRIPTION	QTY
9PBKUSG01	pBK UTE LTD Generic Kit [PP]	1
9PGKUS01	PP Guard Kit Ute Ltd 250x297	1

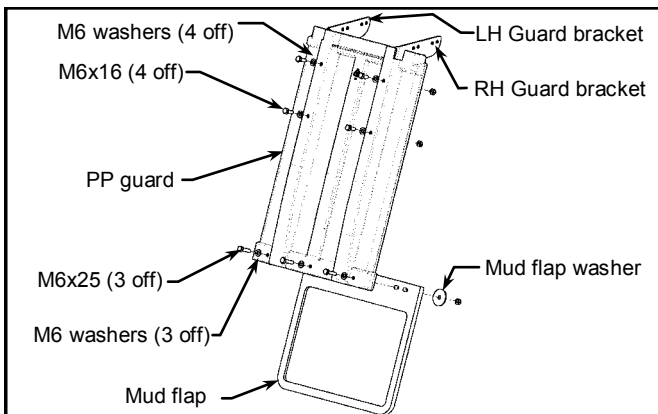

Diagram 4.1: Mudguard with mudflap assembly

STEP 1:

- Place mudflaps on the insides of the 2 rear mudguards, as shown in diagram 4.1.
- Fasten the mudflap to mudguard using 3 x M6x25 bolts from the outside of mudguard through the guard, mudflap & mudflap washer.
- Attach guard brackets to the mudguard using 4 x M6x16 bolts & nyloc nuts, as shown in diagram 4.1.

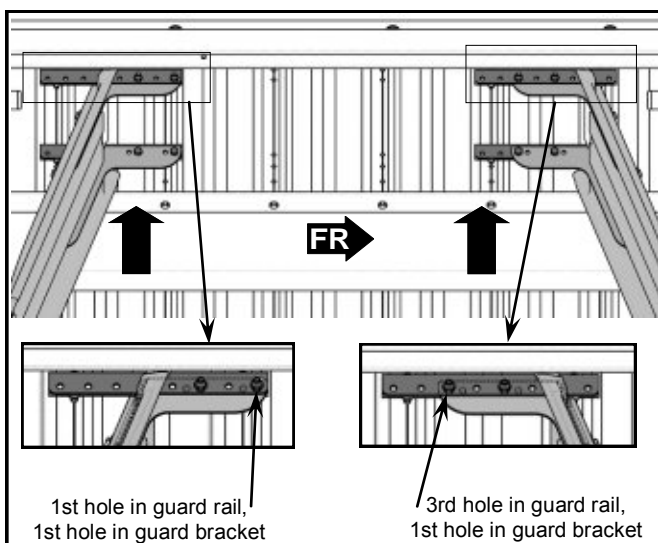

Diagram 4.2: Mudguard to guard rail installation

STEP 2:

- Place mudguard assemblies on the insides of the 2 guard rails.
- Align the mudguard assemblies with the guard rails as shown in diagram 4.2.
- Note position of guard rail to guard bracket when aligning the holes for mudguard assembly.
- Secure mudguard assemblies to guard rails using M6x16 bolts & Nyloc nuts.
- Ensure the bolts are assembled from the inside of the guard rails, with the nuts on the outsides of the guard rails.

ASSEMBLY INSTRUCTION

Colorado / Canyon 1950 QL GPA-HDA Tray

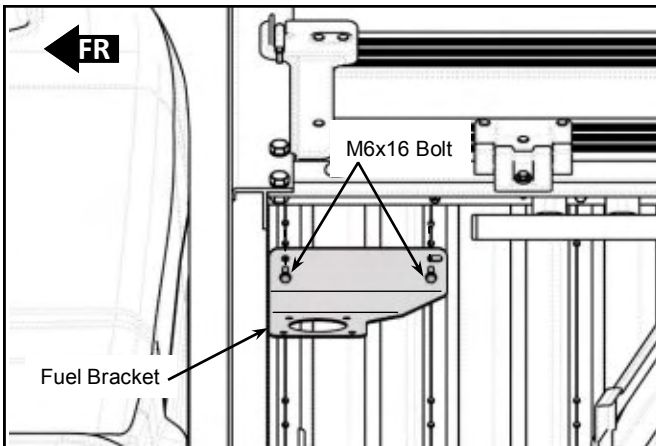

Diagram 4.3: Fuel Filler Bracket Installation

STEP 3:

- Install Fuel Filler bracket to front deck plank, LH side of the tray, aligning holes in bracket with deck plank holes (use holes closest to outboard side of tray). Fasten using M6x16 Bolts & M6 Nyloc Nut.

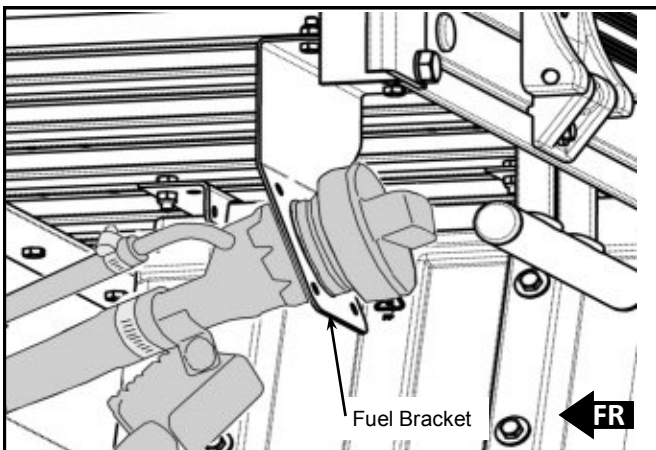

Diagram 4.4: Fuel Filler Bracket Installation

STEP 4:

- Re-orientate the fuel hose to fit to the fuel bracket, ensuring there are no kinks in the fuel or breather hose.
- Ensure there is no less than 10mm gap between fuel hose and tray body and chassis components.



Ensure the breather and fuel lines don't have low points that can trap fuel. Adjust the hoses so fuel will drain to tank.

ASSEMBLY INSTRUCTION

Colorado / Canyon 1950 QL GPA-HDA Tray

Section 5 - Drop Side Assembly

Packs required:

CODE	DESCRIPTION	QTY
9PADQM13C245	pk DS MD QL set 1950x1842x245	1

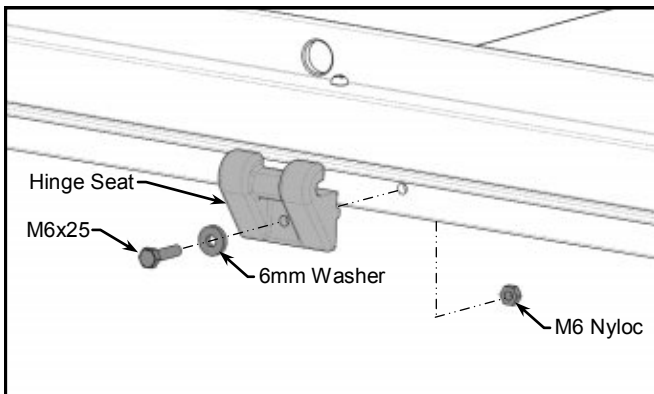

Diagram 5.1: Fitment of hinge seats

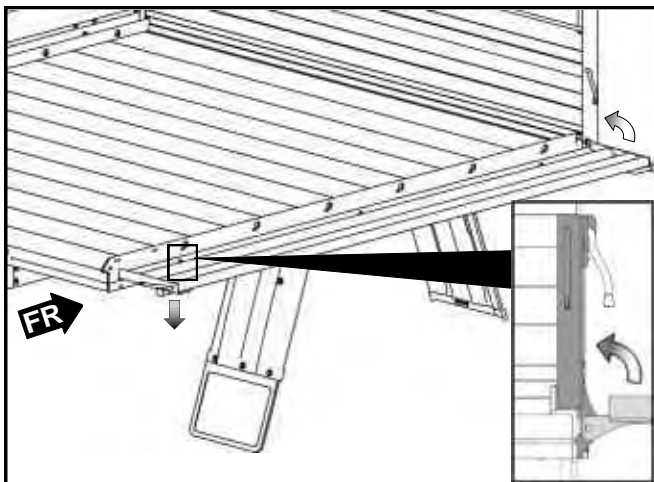

Diagram 5.2: Adjustment of headboard latch

STEP 1:

- Attach 6 x hinge seats to the side coamings (3 x LHS & 3 x RHS) using M6x25 bolts, M6 round washers and nyloc nuts, as shown in diagram 5.1.
- Attach 2 x hinge seats to the rear extrusion panel using M6x25 bolts, M6 round washers and nyloc nuts.

STEP 2:

- Hold the dropside in the horizontal position.
- Place the dropside hinges into the hinge seats.
- Rotate the dropside to be perpendicular and allow the hinge pins to engage into the hinge seats, as shown in diagram 5.2.

Repeat this procedure for the tailgate.

TO DISENGAGE AND REMOVE:

- While the dropside/tailgate is in the horizontal position, gently nudge the entire dropside toward the deck. The hinge pins will disengage from the hinge seats and the dropside/tailgate may then be lifted off the hinge seats.



IMPORTANT - Ensure there is no dirt, sand or gritty substance on the hinge pins or seat before engagement.

ASSEMBLY INSTRUCTION

Colorado / Canyon 1950 QL GPA-HDA Tray

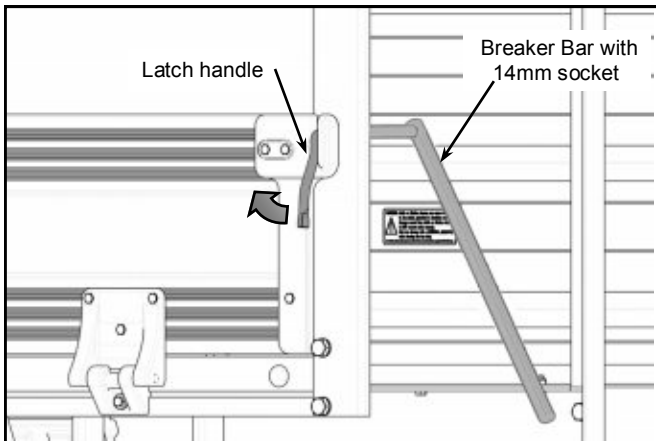

Diagram 5.3: Adjustment of headboard latch.

STEP 3:

- Adjust the latches on the headboard & dropsides by placing a 14mm socket with a breaker bar extension on the Lock Nut.
- Tighten or loosen by turning the latch handle with the dropside lowered.
- Raise the dropside to test. Re-adjust until there is no discernible movement and rattle when the dropside/tailgate is shaken and the latch is still easy to operate.



Correct latch adjustment should occur when the spring washer is compressed by 1-2mm.

ASSEMBLY INSTRUCTION

Colorado / Canyon 1950 QL GPA-HDA Tray

Section 6 - Rear Panel Assembly Procedure

Packs required:

CODE	DESCRIPTION	QTY
9PUSRP01	GM Col Rear Panel kit	1

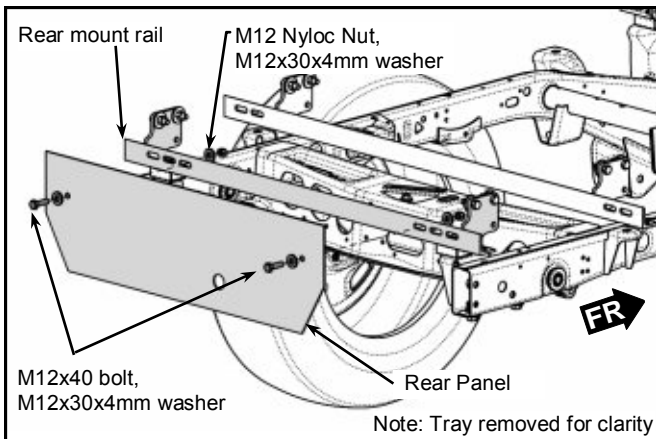
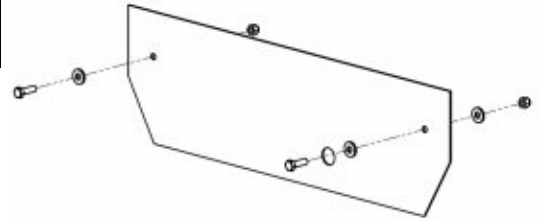

Diagram 6.1: Rear Panel assembly

STEP 1:

- Attach rear panel to the back face of the rear mount rail using M12x40 bolts, M12x30x4mm washers and M21 Nyloc Nut. Do not tighten.
- Insert the grommet to the rear panel hole and align with the spare tire lift tube before tightening bolts.

ASSEMBLY INSTRUCTION

Colorado / Canyon 1950 QL GPA-HDA Tray

Section 7 - Rear Bar Assembly Procedure

Packs required:

CODE	DESCRIPTION	QTY
9PUSR03	GM Col Rear Bar	1

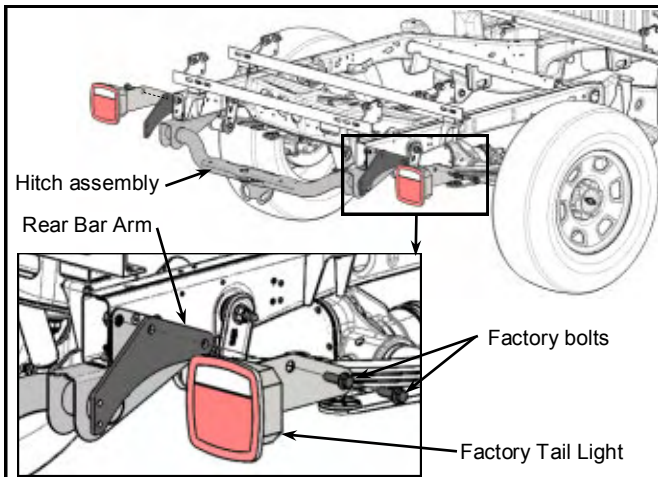
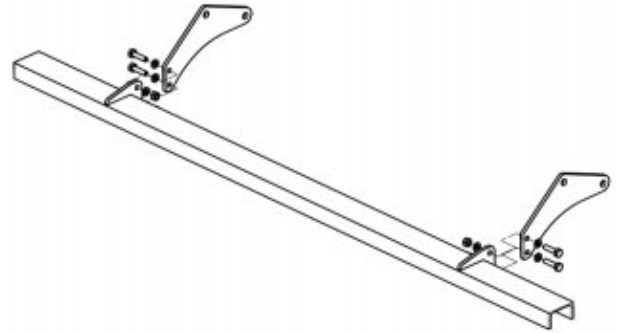

Diagram 7.1: Rear Bar assembly

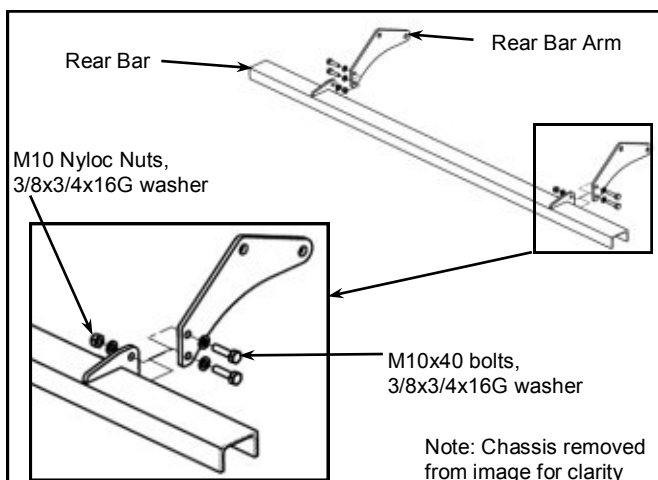

Diagram 7.2: Rear Bar assembly

STEP 1:

- Remove factory bolts (2 each side) that hold the hitch/bumper to the chassis.

STEP 2:

- If there is a set of factory tail lights, they will also be attached to these bolts. If so, remove the factory light brackets and allow lights to hang for now.

STEP 3:

- Align rear bar arm with the bolt holes on the chassis, along with the tail light bracket and attach, using the bolts you previously removed.

STEP 4:

- Rest the rear bar assembly on top of the hitch assembly, padded with a rag or cardboard. You should then be able to easily install all four bolts, attaching the rear bar to the arms using **M10x40 bolts, 3/8x3/4x16G washers and M10 Nyloc Nuts.**

ASSEMBLY INSTRUCTION

Colorado / Canyon 1950 QL GPA-HDA Tray

Section 8 - Completion Procedure

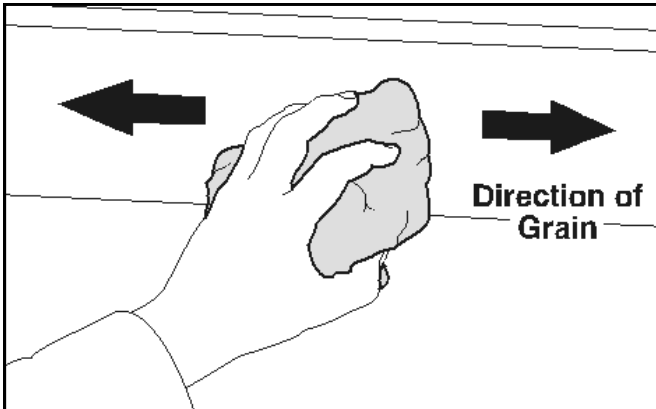

Diagram 8.1: Cleaning of new tray.

STEP 1:

- For cleaning of alloy use soapy water as should be used on the cabin of the vehicle.



Important: Do not use any acidic or caustic based cleaners on your alloy body as they will strip the surface of the alloy and remove the zinc coating from steel components. Many automotive cleaning fluids have high acidic content and high toxicity.

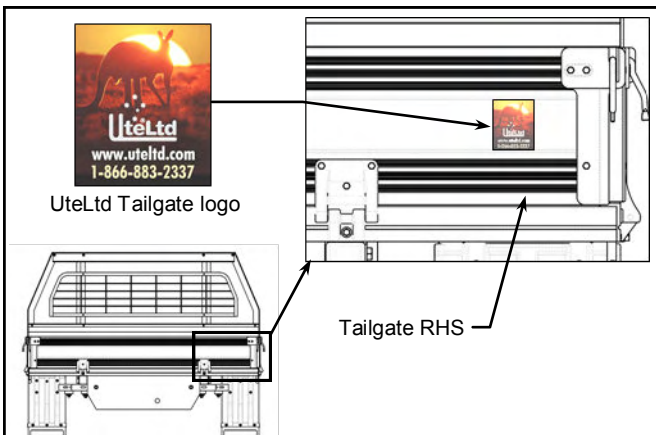

Diagram 8.2: Installing Tailgate Decal

STEP 2:

- Install UteLtd tailgate logo to RH side of the Tailgate as shown in adjacent diagram, ensuring it is central and square.



www.uteltd.com
1-866-883-2337
PO Box 46457
Seattle WA 98146-0457

ASSEMBLY INSTRUCTION

Colorado / Canyon 1950 QL GPA-HDA Tray

APENDIX A - PUSG1SHQ

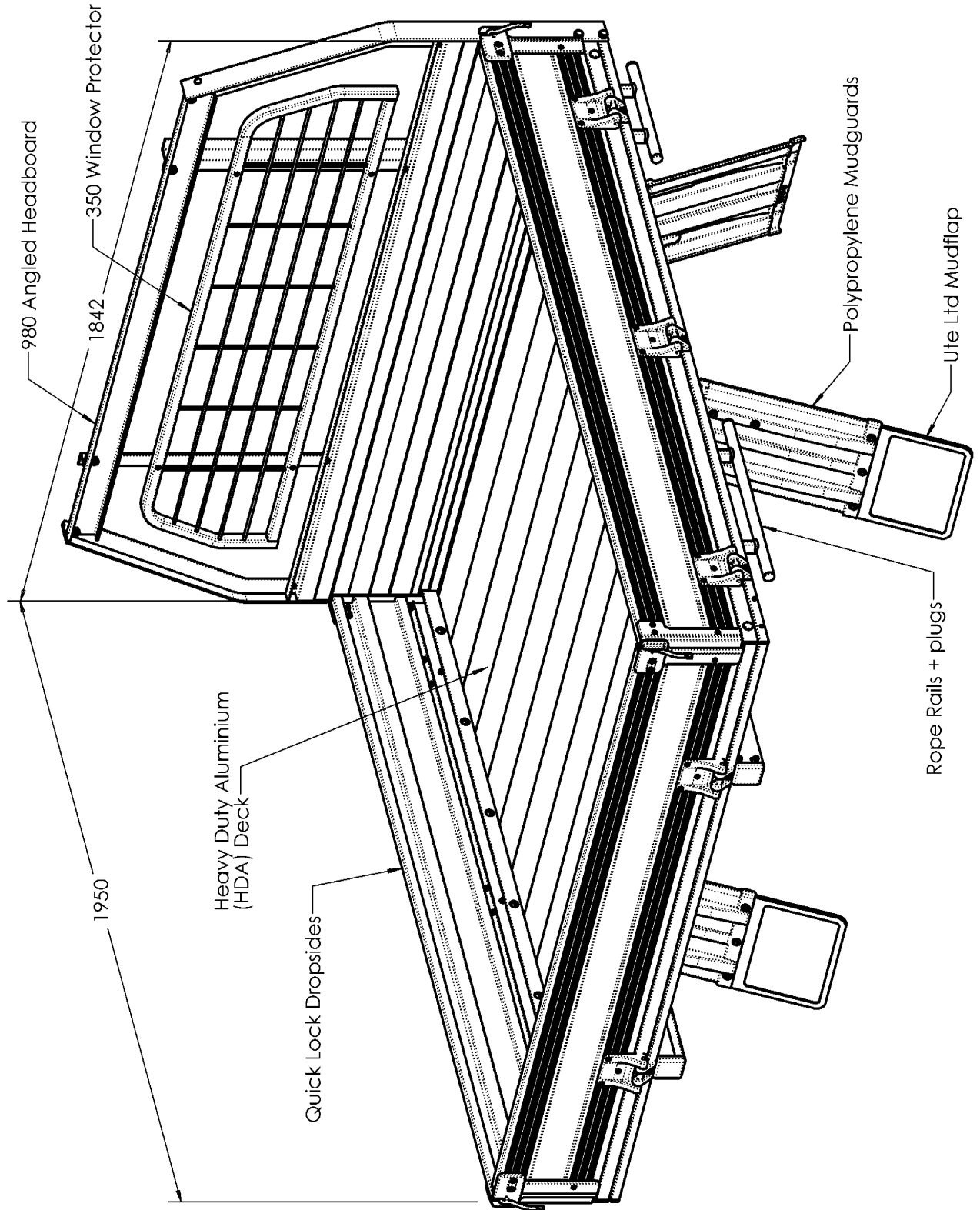

ASSEMBLY INSTRUCTION

Colorado / Canyon 1950 QL GPA-HDA Tray

APPENDIX A - PUSG1SHQ

